

ITALIAN DESIGN LIGHTING

Lamps Collections

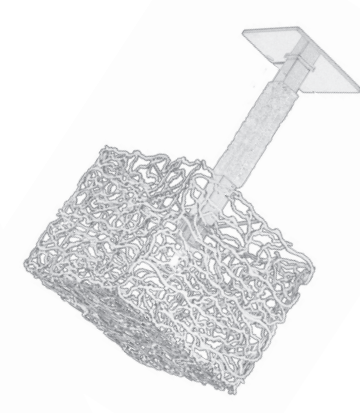

Index

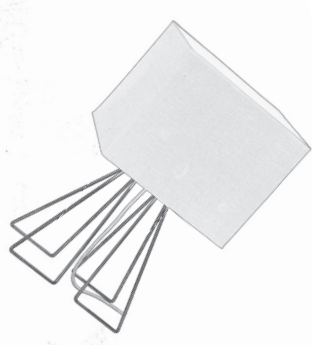
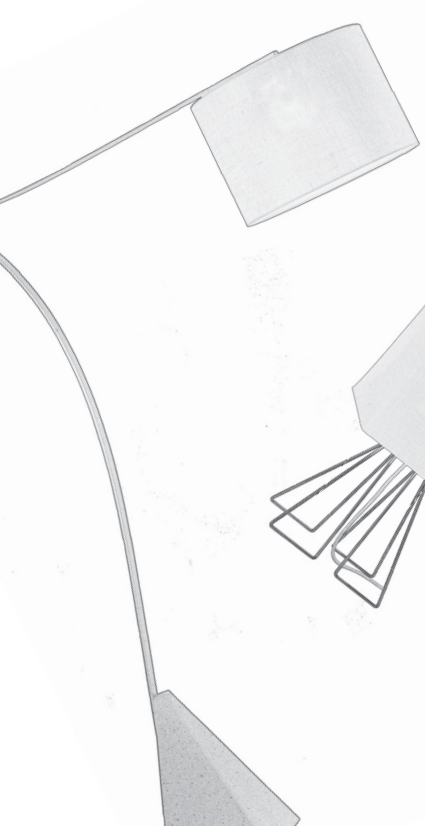
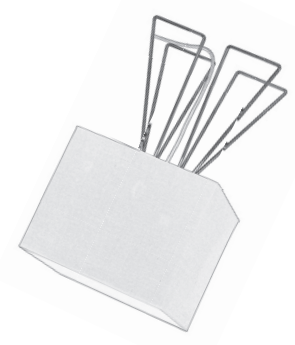

Seventy
page 4



Filoro
page 14



Cocoon
page 24



Charme
page 30



Capitonè
page 48



Glamour
page 52



Vanity
page 58



Woody
page 62



New entries
page 66



Corvy-table
page 72



Twister-outdoor
page 74



Le collezioni
page 78



Seventy

DESIGN Cristian Feltrin

lampada da tavolo/table lamp 589/1L



lampada da terra/floor lamp 588/1P



lampada da tavolo/table lamp 588/1LR



lampada da tavolo/table lamp 589/1L



lampada da tavolo/table lamp 588/1LQ





Seventy

DESIGN Cristian Feltrin

Telaio in metallo disponibile in:
Metal frame available in:



Cavo elettrico disponibile in:
Electrical cable available in:

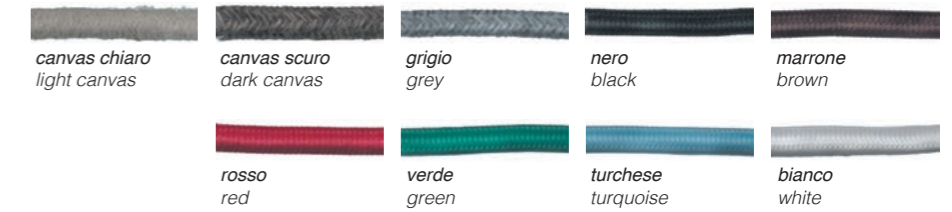

Paralume disponibile in:
Lampshade available in:

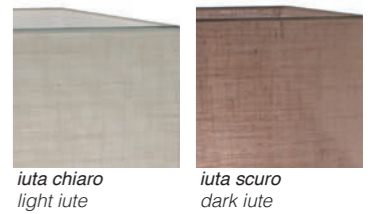

LAMPADA DA TAVOLO TABLE LAMP

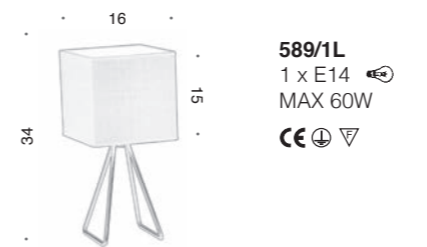

589/1L
1 x E14
MAX 60W
CE ⊕ ▽



589/1L
1 x E14
MAX 60W
CE ⊕ ▽

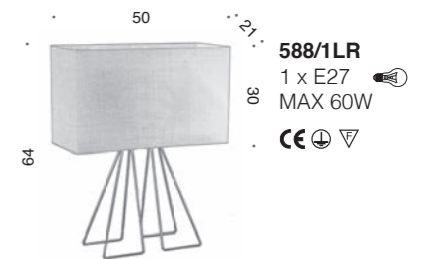

588/1LR
1 x E27
MAX 60W
CE ⊕ ▽

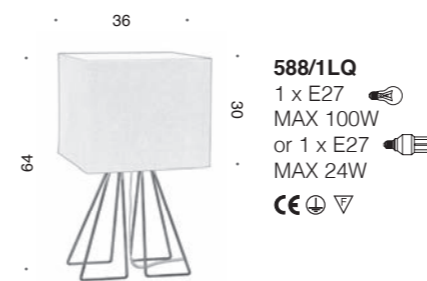

588/1LQ
1 x E27
MAX 100W
or 1 x E27
MAX 24W
CE ⊕ ▽



587/1LG
1 x E27
MAX 100W
or 1 x E27
MAX 24W
CE ⊕ ▽

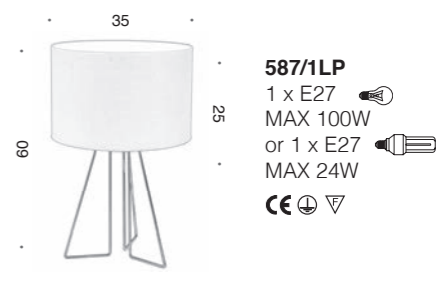

587/1LP
1 x E27
MAX 100W
or 1 x E27
MAX 24W
CE ⊕ ▽

LAMPADA DA TERRA FLOOR LAMP

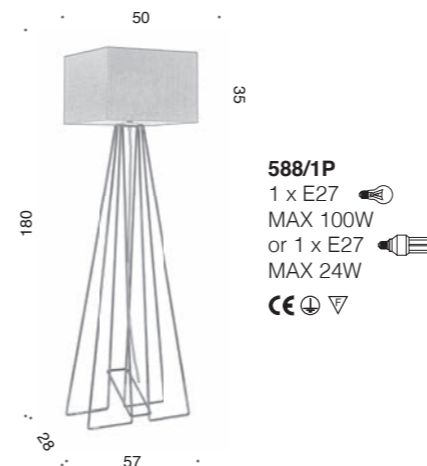

588/1P
1 x E27
MAX 100W
or 1 x E27
MAX 24W
CE ⊕ ▽

lampada da tavolo/table lamp 592/1L



Filozo

DESIGN Cristian Feltrin

lampada da tavolo/table lamp 594/1L



lampada da tavolo/table lamp 590/1L





lampada da tavolo/table lamp 591/1L



lampada da tavolo/table lamp 595/1L



lampada da tavolo/table lamp 593/1L





Filoro

DESIGN Cristian Feltrin

Telaio in metallo disponibile in:
Metal frame available in:

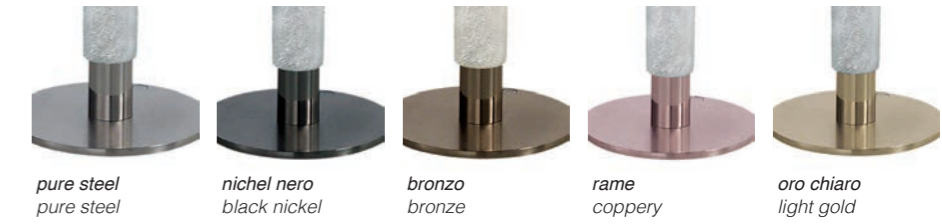

pure steel
pure steel

nichel nero
black nickel

bronzo
bronze

rame
coppery

oro chiaro
light gold

Paralume disponibili in:
Lampshade available in:

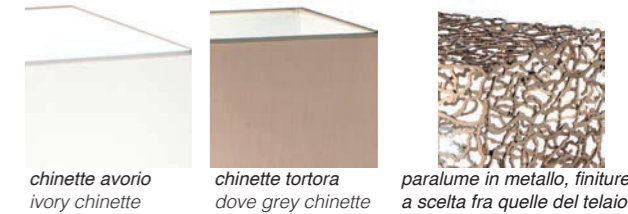

chinette avorio
ivory chinette

chinette tortora
dove grey chinette

paralume in metallo, finiture a scelta fra quelle del telaio
metal lampshade, finishes chosen from those of the frame

LAMPADA DA TAVOLO TABLE LAMP



590/1L
1 x E27
MAX 100W
or 1 x E27
MAX 24W
CE ⊕ ▽



594/1L
1 x E27
MAX 100W
or 1 x E27
MAX 24W
CE ⊕ ▽

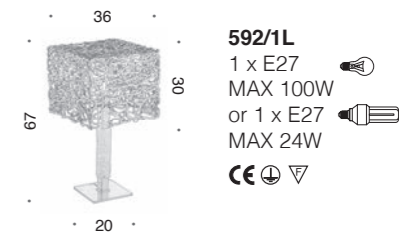

592/1L
1 x E27
MAX 100W
or 1 x E27
MAX 24W
CE ⊕ ▽



591/1L
1 x E27
MAX 100W
or 1 x E27
MAX 24W
CE ⊕ ▽

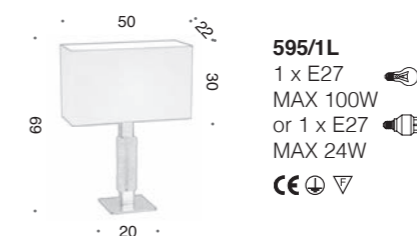

595/1L
1 x E27
MAX 100W
or 1 x E27
MAX 24W
CE ⊕ ▽



593/1L
1 x E27
MAX 100W
or 1 x E27
MAX 24W
CE ⊕ ▽



Cocoon

DESIGN Cristian Feltrin



sospensione/suspension 586/4S



lampada da tavolo/table lamp 586/3L

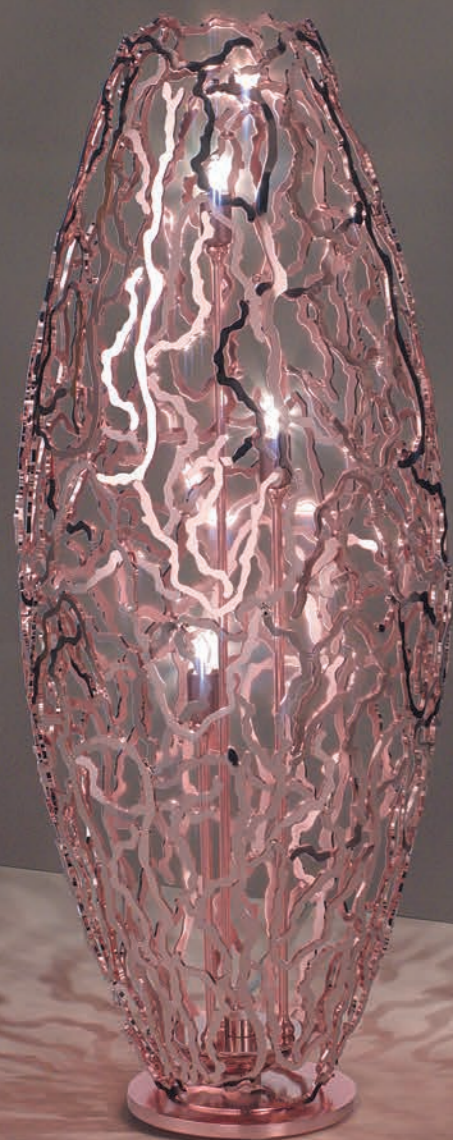

lampada da tavolo/table lamp 586/5L



Cocoon

DESIGN Cristian Feltrin

lampada da tavolo/table lamp 586/1LP



lampada da tavolo/table lamp 586/1LG



Telaio in metallo disponibile in:
Metal frame available in:



*rame
rose gold*



*rame antico
antique coppery*



*pure steel
pure steel*



*bronzo
bronze*



*oro chiaro
light gold*



*nicel nero opaco
light gold*

LAMPADA DA TAVOLO TABLE LAMP

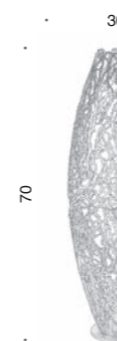

586/3L
3 x G9
MAX 33W
CE ⊕ ▽

586/1LP
1 x LED 13W
1000 lumen
2700K
CE ⊕ ▽

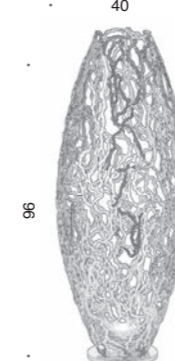

586/5L
5 x G9
MAX 33W
CE ⊕ ▽

586/1LG
1 x LED 13W
1000 lumen
2700K
CE ⊕ ▽

SOSPENSIONE SUSPENSION



586/4S
4 x G9
MAX 33W
CE ⊕ ▽

lampada da terra/floor lamp 600/13P



Charme

DESIGN Cristian Feltrin

lampada da terra/floor lamp 600/7P



lampada da terra/floor lamp 600/9P



lampada da terra/floor lamp 600/13P



lampada da tavolo/table lamp 601/1LM





lampada da tavolo/table lamp 601/1LM



tavolino/table TA06045 D.63xH58



lampada da tavolo/table lamp 601/1LG



lampada da tavolo/table lamp 600/1LG



lampada da tavolo/table lamp 600/1LP



lampada da tavolo/table lamp 600/1LM



lampada da tavolo/table lamp 600/1LG



lampada da tavolo/table lamp 600/1LP

lampada da tavolo/table lamp 600/1LM



lampada da tavolo/table lamp 600/1LG



Charme

DESIGN Cristian Feltrin

Telaio in metallo disponibile in:
Metal frame available in:

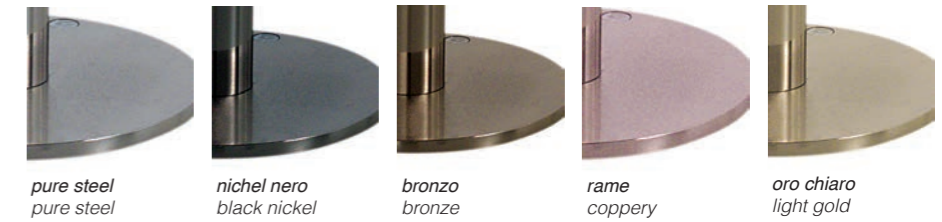

pure steel
pure steel

nichel nero
black nickel

bronzo
bronze

rame
coppery

oro chiaro
light gold

Paralume disponibile in:
Lampshade available in:

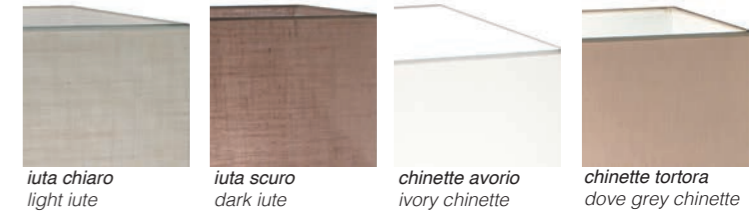

iuta chiaro
light iute

iuta scuro
dark iute

chinette avorio
ivory chinette

chinette tortora
dove grey chinette

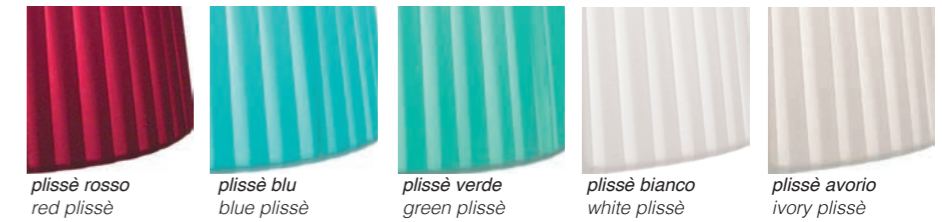

plissé rosso
red plissé

plissé blu
blue plissé

plissé verde
green plissé

plissé bianco
white plissé

plissé avorio
ivory plissé

Vetro decorativo disponibile in:
Decorative glass available in:



crystallo
crystal

ambra
amber

fumè
fumè

azzurro
light blue

verde
green

bianco
white

nero
black

LAMPADA DA TAVOLO TABLE LAMP



601/1LG
1 x E27
MAX 100W
or 1 x E27
MAX 24W
CE ⊕ ▽



601/1LM
1 x E27
MAX 100W
or 1 x E27
MAX 24W
CE ⊕ ▽



600/1LG
1 x E27
MAX 100W
or 1 x E27
MAX 24W
CE ⊕ ▽

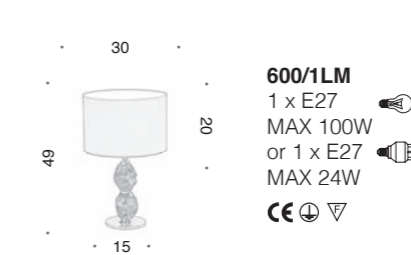

600/1LM
1 x E27
MAX 100W
or 1 x E27
MAX 24W
CE ⊕ ▽



600/1LP
1 x E27
MAX 100W
or 1 x E27
MAX 24W
CE ⊕ ▽

LAMPADA DA TERRA FLOOR LAMP

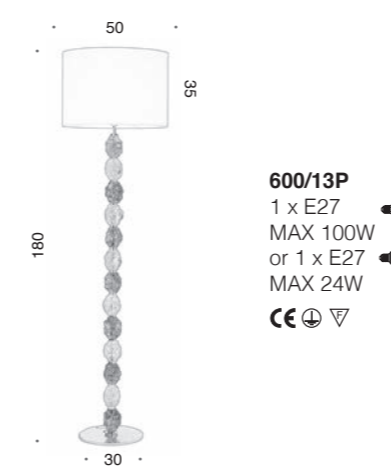

600/13P
1 x E27
MAX 100W
or 1 x E27
MAX 24W
CE ⊕ ▽

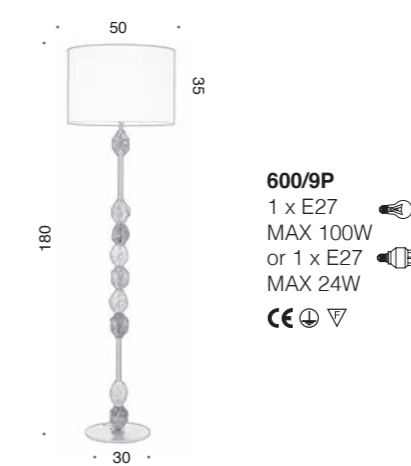

600/9P
1 x E27
MAX 100W
or 1 x E27
MAX 24W
CE ⊕ ▽

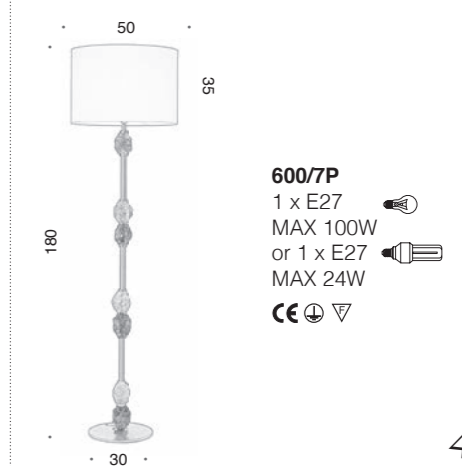

600/7P
1 x E27
MAX 100W
or 1 x E27
MAX 24W
CE ⊕ ▽

lampada da terra/floor lamp 487/1P



Capitone

DESIGN Cristian Feltrin



lampada da terra/floor lamp 487/1P

lampada da tavolo/table lamp 487/1LG



Capitonné

DESIGN Cristian Feltrin

Telaio in metallo disponibile in:
Metal frame available in:

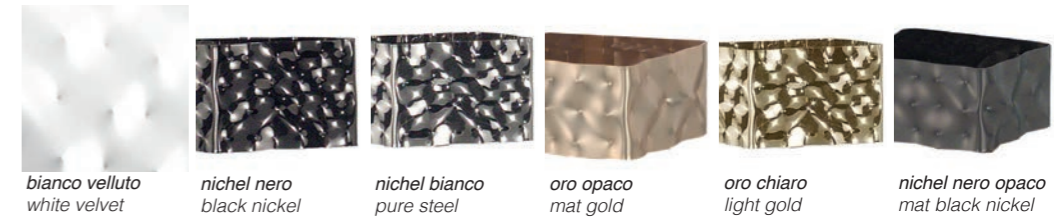

Paralume disponibile in:
Lampshade available in:

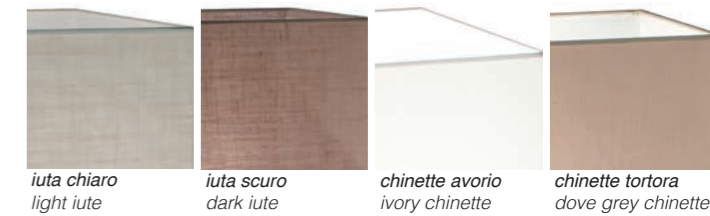

LAMPADA DA TAVOLO TABLE LAMP

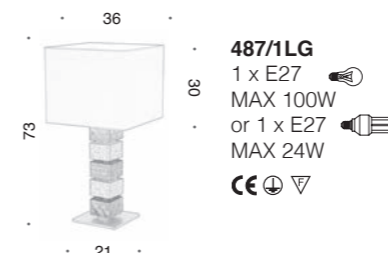

487/1LG
1 x E27
MAX 100W
or 1 x E27
MAX 24W
CE Ⓢ Ⓣ

LAMPADA DA TERRA FLOOR LAMP

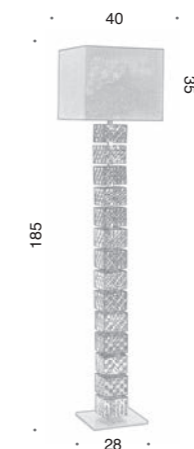

487/1P
1 x E27
MAX 100W
or 1 x E27
MAX 24W
CE Ⓢ Ⓣ

lampada da tavolo/table lamp 462/1LG



Glamour

DESIGN Cristian Feltrin





Glamour

DESIGN Cristian Feltrin

Telaio in metallo disponibile in:
Metal frame available in:



nichel nero
black nickel



pure steel
pure steel

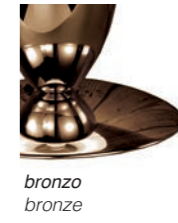

bronz
bronz



rame
coppery



oro chiaro
light gold

Paralume disponibile in:
Lampshade available in:



plissé avorio
ivory plissé

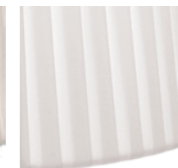

plissé avorio
ivory plissé



per art.462: paralume in metallo, finiture a scelta fra quelle del telaio
for article 462: metal lampshade, finishes chosen from those of the metal frame

LAMPADA DA TAVOLO TABLE LAMP



462/1LG
1 x E27
MAX 100W
or 1 x E27
MAX 24W
CE ⊕ ▽



531/1L
1 x E27
MAX 100W
or 1 x E27
MAX 24W
CE ⊕ ▽



583/1L
1 x E27
MAX 100W
or 1 x E27
MAX 24W
CE ⊕ ▽



Vanity

DESIGN Cristian Feltrin



tavolino/coffee table TA06035 L.80xP80xH47

poltrona in pelle/leather armchair DV0530PEA L.69xP78xH101



Vanity

DESIGN Cristian Feltrin

Telaio in metallo disponibile in:
Metal frame available in:

Per la collezione 585 le sfere sono in metallo e vetro, mentre nella serie 484 sono tutte in metallo.

For the collection 585 the spheres are in metal and transparent glass, instead for the collection 484 the spheres are all in metal.

Paralume disponibile in:
Lampshade available in:



nichel nero
black nickel



pure steel
pure steel



bronzo
bronze



rame
coppery



oro chiaro
light gold



plissé avorio
ivory plissé



plissé bianco
white plissé



chinette avorio
ivory chinette



chinette tortora
dove grey chinette

LAMPADA DA TAVOLO TABLE LAMP



585/1L
1 x E27
MAX 100W
or 1 x E27
MAX 24W
CE Ⓢ Ⓣ



584/1L
1 x E27
MAX 100W
or 1 x E27
MAX 24W
CE Ⓢ Ⓣ



sospensione/suspension 570/200SG

sospensione/suspension 570/200SP



Woody

DESIGN Cristian Feltrin

lampada da tavolo/table lamp 568/200L



Woody

DESIGN Cristian Feltrin

legno rovere disponibile in:
oak wood available in:

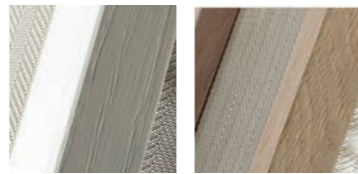

legno rovere
bianco
white oak wood

legno rovere
naturale
natural oak wood

SOSPENSIONE SUSPENSION

LAMPADA DA TAVOLO TABLE LAMP

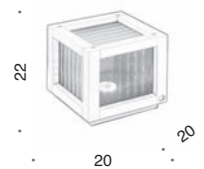

568/200L
1 x LED 8W
850 lumen 2700K
CE Ⓢ Ⓡ

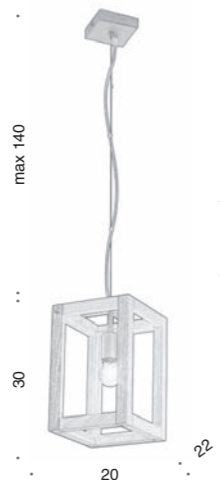

570/200SG
1 x E27
MAX 100W
or 1 x E27
MAX 24W
CE Ⓢ Ⓡ

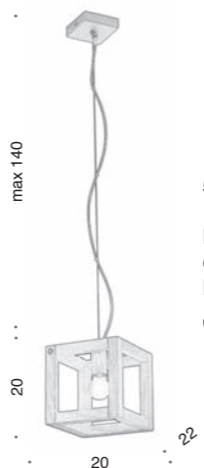

570/200SP
1 x E27
MAX 100W
or 1 x E27
MAX 24W
CE Ⓢ Ⓡ

sospensione/suspension 570/200SG



sospensione/suspension 570/200SP

lampada da terra/floor lamp 9026/1P



New entries

DESIGN Cristian Feltrin



tavolino in pelle/gueridon table with top in leather TA06020 D.70xH60
poltrona in pelle/leather armchair DV0530PEA L.69xP78xH101

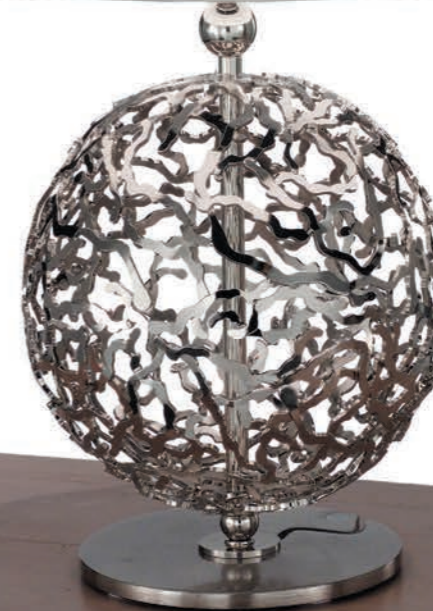

lampada da terra/floor lamp 4271P



lampada da tavolo/table lamp 3071LG





Disponibili realizzazioni su misura.
Custom made sizes available.

Corvy-table

DESIGN Cristian Feltrin

TAVOLINO TABLE

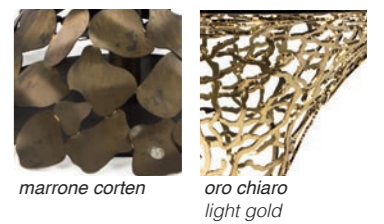
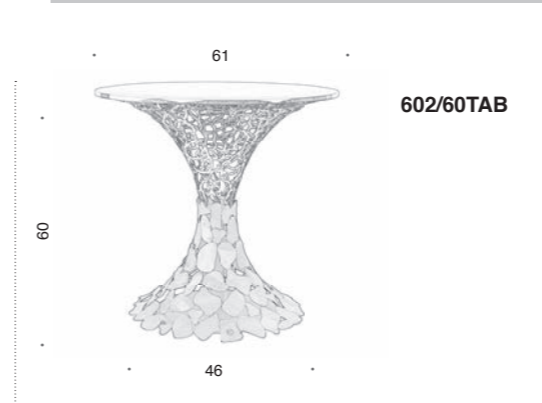

La struttura in metallo è disponibile, su richiesta, in altre finiture.
The Metal frame is available, upon request, in other finishings.



Twister-outdoor

DESIGN Cristian Feltrin

Telaio in metallo disponibile in:
Metal frame available in:



ruggine
rust

Sfera interna in polietilene disponibile in:
The sphere inside is in polyethylene available in:

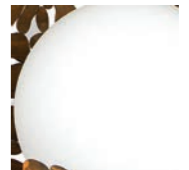

bianco
white

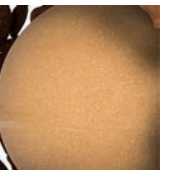

marrone
brown

LAMPADA DA TERRA FLOOR LAMP

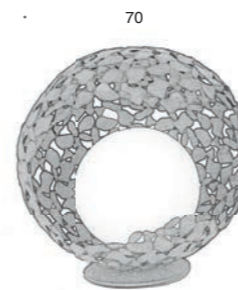

70

509/8LOUT
1 x E27
MAX 46W
or 1 x E27
MAX 20W
IP65
CE □ ▽

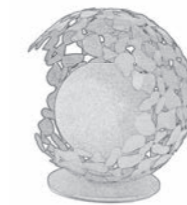

50

509/6LOUT
1 x E27
MAX 46W
or 1 x E27
MAX 20W
IP65
CE □ ▽

Atena

DESIGN Cristian Feltrin

LAMPADA DA TERRA FLOOR LAMP

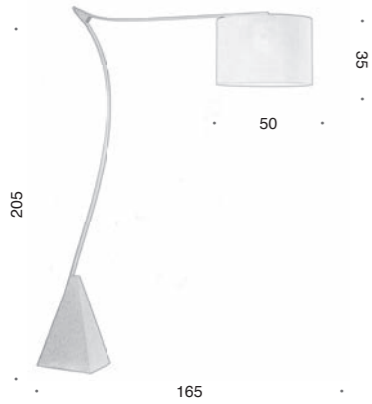

9026/1P
1 x E27
MAX 100W
or 1 x E27
MAX 24W
CE ⊕ ▽

Telaio in metallo disponibile in:
Metal frame available in:

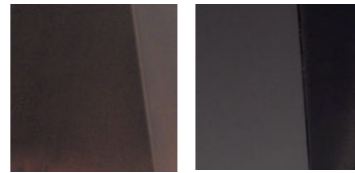

ruggine
rusty *nichel nero*
black nickel

Paralume disponibile in:
Lampshade available in:



iuta chiaro
light iute *chinette avorio*
ivory chinette *iuta scuro*
dark iute *chinette tortora*
dove grey chinette

Weave

DESIGN Cristian Feltrin

LAMPADA DA TAVOLO TABLE LAMP



511/1L
1 x E27
MAX 100W
or 1 x E27
MAX 24W
CE ⊕ ▽

Telaio in metallo disponibile in:
Metal frame available in:



pure steel
pure steel *bronzo*
bronze *rame*
coppery *oro chiaro*
light gold

Paralume disponibile in:
Lampshade available in:



iuta chiaro
light iute *chinette avorio*
ivory chinette *iuta scuro*
dark iute *chinette tortora*
dove grey chinette

Itak

DESIGN Cristian Feltrin

LAMPADA DA TAVOLO TABLE LAMP



307/1LG
1 x E27
MAX 100W
or 1 x E27
MAX 24W
CE ⊕ ▽

Telaio in metallo disponibile in:
Metal frame available in:



pure steel
pure steel *bronzo*
bronze *rame*
coppery *oro chiaro*
light gold



vetro Murano
trasparente
transparent
Murano glass

Bubbles

DESIGN Cristian Feltrin

LAMPADA DA TERRA FLOOR LAMP

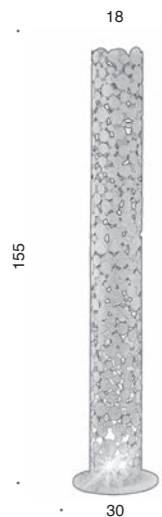

427/1P
1 x LED 13W
1000 lumen
2700K
CE ⊕ ▽

Telaio in metallo disponibile in:
Metal frame available in:



ruggine
rust *bianco velluto*
white velvet *nero velluto*
black velvet

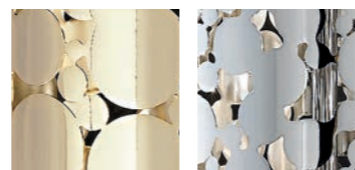

oro chiaro
light gold *cromo*
chrome

Chrysalis

DESIGN Cristian Feltrin

LAMPADA DA TAVOLO TABLE LAMP



448/1LG
1 x E27
MAX 100W
or 1 x E27
MAX 24W
CE ⊕ ▽

Telaio in metallo disponibile in:
Metal frame available in:



avorio lucido
soft ivory *oro chiaro*
light gold *pure steel*
pure steel *black aubergine*
black aubergine *nichel nero*
black nickel

Paralume disponibile in:
Lampshade available in:



plissé avorio
ivory plissé



Le collezioni



comò/dresser CO21015 L.137xP54xH104

lampada da tavolo/table lamp LP80031



lampada da tavolo/table lamp LP80028



comò decorato/hand-decorated sideboard CO21003 L.137xP51xH94



lampada da tavolo/table lamp LP80027

consolle/console table CN0900 L.142xP47xH88

Le collezioni

LAMPADA DA TAVOLO TABLE LAMP

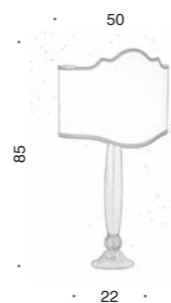

LP80027
1 x E27
MAX 100W
or 1 x E27
MAX 24W
CE ⊕ ▽



LP80028
1 x E27
MAX 100W
or 1 x E27
MAX 24W
CE ⊕ ▽



LP80029
1 x E27
MAX 100W
or 1 x E27
MAX 24W
CE ⊕ ▽



LP80030
1 x E27
MAX 100W
or 1 x E27
MAX 24W
CE ⊕ ▽

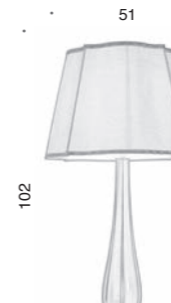

LP80031
1 x E27
MAX 100W
or 1 x E27
MAX 24W
CE ⊕ ▽



LP80032
1 x E27
MAX 100W
or 1 x E27
MAX 24W
CE ⊕ ▽

Indice analitico | Analytical index

Codice Articolo Article code	Pagina Page	Codice Articolo Article code	Pagina Page	Codice Articolo Article code	Pagina Page	Codice Articolo Article code	Pagina Page
ITAK		GLAMOUR		SEVENTY		CORVY-TABLE	
307/1LG	71	531/1L	54	587/1LG	11	602/60TAB	72-73
BUBBLES		WOODY		587/1LP		ATENA	
427/1P	70	568/200L	63	588/1LQ	9	9026/1P	66
CHRYSALIS		570/200SG		588/1LR		LE COLLEZIONI	
448/1LG	68	570/200SP	62-65	588/1P	8	LP80027	84
GLAMOUR		GLAMOUR		589/1L		LP80028	
462/1LG	52-56	583/1L	55	589/1L		LP80029	
CAPITONNE'		VANITY		590/1L		LP80030	
487/1LG	51	584/1L	61	591/1L	17	LP80031	82
487/1P	48-50	585/1L	58-60	592/1L	18-19	LP80032	78
TWISTER-OUTDOOR		COCOON		593/1L		594/1L	
509/6LOUT	74-75	586/1LG	29	595/1L	21	595/1L	
509/8LOUT	74-75	586/1LP	29	CHARME		600/1LG	
WEAVE		586/3L		600/1LM		40-43-45	
511/1L	69	586/5L	24-28	600/1LP	41-44	600/1LP	
		586/4S		600/7P		40-43	
				600/9P		32	
				600/13P		32	
				601/1LG		30-33	
				601/1LM		38-39	
						34-35-36-37	

CLASSI ENERGETICHE

Energy classes

Attacco Bulb type	Questo dispositivo è compatibile con lampadine di classi energetiche: This luminaire is compatible with bulbs of the energy classes:	Il dispositivo è venduto con una lampadina di classe energetica: This luminaire is sold with bulbs of the energy classes:	Collezione Collection
G9	DA A++ AD E FROM A++ TO E		COCOON
E27 / E14	DA A++ AD E FROM A++ TO E	_____	SEVENTY, FILORO, CHARME, CAPITONNE', GLAMOUR, VANITY, WOODY, NEW ENTRIES, TWISTER-OUTDOOR, LE COLLEZIONI
LED	DA A++ AD A FROM A++ TO A	Le lampade di questo dispositivo non sono sostituibili The lamps cannot be changed in the luminaire	COCOON, WOODY

Condizioni generali di vendita

1) VALIDITÀ E DIRITTO DI MODIFICA

a - Qualsiasi contratto tra I.D.L. Export S.r.l. (in prosieguo indicata come " il Venditore ") per la fornitura di suoi prodotti a un cliente (in prosieguo indicato come " l'Acquirente ") sarà disciplinato dalle presenti Condizioni Generali di Vendita che sostituiscono tutte le precedenti Condizioni Generali di Vendita.

b - Il Venditore si riserva il diritto di modificare le presenti Condizioni Generali di Vendita, allegando tali modifiche alle offerte, alle conferme o a qualsivoglia corrispondenza inviata all'Acquirente.

2) ACCETTAZIONE DEGLI ORDINI

a - Qualsivoglia ordine dell'Acquirente diverrà impegnativo solo se effettuato in forma scritta, anche via fax, e se espressamente confermato per iscritto dal Venditore, anche via fax.

3) CATALOGHI E LISTINI

a - Cataloghi, listini prezzi e altro materiale promozionale, benché redatto e fornito in buona fede, costituisce solo una indicazione del tipo di prodotti e di prezzi e le informazioni ivi indicate non sono impegnative per il Venditore; in particolare le fotografie dei prodotti non rappresentano un campione degli stessi.

4) CONSEGNA

a - Salvo patto contrario la consegna dei prodotti s'intende franco fabbrica e ciò anche quando sia convenuto che la spedizione o parte di essa venga curata dal Venditore.

b - I rischi di perimento passano all'Acquirente al momento della consegna dei prodotti al primo vettore o spediziere presso lo stabilimento del Venditore, indipendentemente da chi sia tenuto a sopportare le spese di trasporto. Con tale rimessa al primo vettore o spediziere il venditore ha adempiuto all'obbligo di consegna.

c - Il termine di consegna indicato nella Conferma d'Ordine è indicativo e non vincolante.

5) TERMINI E CONDIZIONI DI PAGAMENTO

a - Il prezzo deve essere pagato nel luogo ove il Venditore ha la sua sede.

b - Il Venditore può opporre il pagamento dell'intero prezzo come condizione della consegna dei prodotti.

c - In caso di ritardato pagamento rispetto alla data pattuita l'Acquirente sarà automaticamente tenuto a corrispondere interessi di mora senza che vi sia

bisogno di alcuna richiesta o altra formalità da parte del Venditore.

6) DENUNCIA DIFETTI

a - Qualora non l'abbia già effettuata, l'Acquirente ha l'onere di effettuare piena ed attenta verifica dei prodotti non appena questi gli siano stati effettivamente consegnati.

b - L'Acquirente decade dal diritto di far valere un difetto di conformità o di vizio o una mancanza di qualità dei prodotti se non ne fa denuncia in forma scritta al Venditore, precisando la natura del difetto, entro 10 giorni dalla data in cui i prodotti gli sono stati effettivamente consegnati.

7) GARANZIE DEL VENDITORE

a - Salvo il caso di dolo o colpa grave, in caso di difetto di conformità o di vizi o di mancanza di qualità dei prodotti, il Venditore sarà tenuto unicamente alla riparazione degli stessi. L'Acquirente non potrà esigere altri prodotti in sostituzione a meno che il difetto non costituisca una inosservanza essenziale del contratto e tale richiesta sia stata fatta al momento della sua denuncia. Rimane inteso che l'obbligo di riparare o sostituire i prodotti esclude ogni altra responsabilità del venditore per risarcimento danni.

8) LEGGE APPLICABILE

a - Il contratto è disciplinato dalla legge italiana e, per quanto riguarda le obbligazioni contrattuali, viene esclusa l'applicazione delle norme di diritto internazionale privato italiano e dunque ogni rinvio che esse dovessero fare alla legge di altri paesi o a convenzioni internazionali.

9) FORO COMPETENTE ESCLUSIVO

a - Per ogni controversia derivante dal contratto o ad esso connessa è competente in via esclusiva il Foro di Castelfranco Veneto (Tribunale di Treviso sezione distaccata di Castelfranco Veneto o Giudice di Pace di Castelfranco Veneto). L'Acquirente dichiara di conoscere ed approvare le condizioni generali di contratto riportate sul catalogo/ listino prezzi e sul retro della proposta di commissione di cui in particolare approva specificatamente le clausole di seguito richiamate:5b-; pagamento del prezzo come condizione di consegna; 6b - decadenza dal diritto di far valere un difetto di conformità o un vizio o una mancanza di qualità dei prodotti; 7a- limitazione di responsabilità; 9a - foro competente esclusivo.

General sales conditions

1) VALIDITY AND RIGHT OF CHANGE

a - Any contract between I.D.L. Export S.r.l. (from now on it will be indicated as "Seller") and a customer (from now on it will be indicated as "Buyer") concerning the supply of IDL articles will be regulated by the following General Conditions of Sale that replace all the previous General Conditions of Sales.

b - The Seller reserves the right to modify these General Conditions of Sale by enclosing the changes in the offers, in the order confirmations or in any other correspondence with the Buyer.

2) ORDER ACCEPTANCE

a - Any order placed by the Buyer will be binding for the Seller only if made in writing (also by fax) and only if confirmed in writing by the Seller (also by fax).

3) CATALOGUE AND PRICE LIST

a - Catalogues, price lists and advertising material are drawn up in good faith; anyway the information enclosed is not binding for the Seller and it serves as indication of the articles that will be sold and their price. In particular the pictures of the products do not represent a sample of them.

4) DELIVERY

a - Different agreement excepted, the delivery of the goods is supposed to be EX WORKS even if the parties of the contract decide that the Seller must take care of the dispatch or of a part of it.

b - The risk concerning the damage of the goods is transferred to the Buyer when the goods are delivered to the first carrier or to the forwarding agent in the Seller's premises. This risk passes to the Buyer independently of the part that must meet the transports cost. The Seller will fulfil the delivery's obligation by giving the goods to the first carrier or to the forwarding agent.

c - The delivery date indicated on the Order Confirmation is just indicative and not binding.

5) CONDITIONS OF PAYMENT

a - The price must be paid to the Seller's head offices.

b - The Seller can require the payment of the whole price as essential condition for the delivery of the goods.

c - In case of delayed payment the Buyer must automatically pay interests of arrears without any special Seller's request.

6) NOTIFICATION OF DEFECTS

a - Unless the Buyer has already checked the goods, he must check them as soon as he receives them.

b - In case of conformity defects, vices or bad quality, the Buyer loses the possibility to exercise his right if he does not complain in writing to the Seller within 10 days from the receipt of the goods and by specifying the nature of the defect he is complaining about.

7) GUARANTEE

a - Fraud and heavy fault excepted, in case of conformity defects, vices or bad quality, the Seller must only repair the complained items. The Buyer cannot require the replacement of the products unless the defect represents an essential non-observance of the contract and if this request was made when this defect was declared. The replacement of the goods or the reparation of them let the Seller free from any other obligation concerning the claim for damages.

8) LAW ENFORCEABLE

a - The present contract is regulated by the Italian Law. As for the contract's obligations, the enforcement of the International Italian private law is excluded and also any reference to the international law or to the law of other countries.

9) SOLE COMPETENT FORUM

a - For any dispute concerning the contract the sole competent forum is in Castelfranco Veneto (Court of Treviso, Department of Castelfranco Veneto or Justice of Peace of Castelfranco Veneto). The Buyer declares to know and to accept the General Conditions of Sale indicated in the catalogue/ the price list and on the back of the trial commission order. In particular the Buyer accepts the following clauses:

5b - payment of the whole price as condition for the delivery; 6b - losing of the right to comply a conformity defect, vice or the bad quality of the products; 7a - limit liability; 9a - sole competent forum.



La marcatura CE è la certificazione che definisce che tutti i prodotti IDL Export Srl sono verificati secondo le normative europee di sicurezza, in base alle norme seguenti: The CE mark is the certification wich defines that all products of IDL Export Srl are conforming the European security regulations, as per following rules:

CEI EN 60598-1	prescrizione generali e prove / general requirements and tests
CEI EN 60598-2-1	apparecchi di illuminazione fissi per uso generale / fixed lighting equipments for general use
CEI EN 60598-2-4	apparecchi di illuminazione mobili per uso generale / mobile lighting equipments for general use
CEI EN 60598-2-6	apparecchi di illuminazione con trasformatore incorporato per lampade ad incandescenza / lighting equipments with built-in transformer for incandescent lamps

IP20 Indica la resistenza offerta dall'apparecchio alla penetrazione di solidi e liquidi, denominata con il codice IP (International Protection) e seguita da due cifre, 2 che indica il grado di protezione contro l'ingresso di corpi solidi (protetto per corpi di dimensioni superiori a 12mm) e 0, che indica il grado di protezione contro l'ingresso di corpi liquidi (non protetto). Indicates the resistance given by the lighting fitting to the penetration of solids and liquids, stated by the code IP (International Protection) and followed by two digits, 2 which means the rate of protection against the entry of solid parts (protected against entry of solid parts with dimensions more than 12mm), and 0, which indicates the rate of protection against the entry of liquid parts (not protected).

IP65 Indica la resistenza offerta dall'apparecchio alla penetrazione di solidi e liquidi, denominata con il codice IP (International Protection) e seguita da due cifre, 6 che indica il grado di protezione contro l'ingresso di corpi solidi (protetto completamente contro la penetrazione della polvere) e 5, che indica il grado di protezione contro l'ingresso di corpi liquidi (protetto contro i getti d'acqua). Indicates the resistance given by the lighting fitting to the penetration of solids and liquids, stated by the code IP (International Protection) and followed by two digits, 6 which means the rate of protection against the entry of solid parts (completely protected against entry of dust), and 5, which indicates the rate of protection against the entry of liquid parts (protected against water jets).



CLASSE I Apparecchi con parti metalliche costantemente collegate al circuito terra
Equipments with metal parts constantly connected to the earth circuit.



CLASSE II Apparecchi provvisti di doppio isolamento o isolamento rinforzato e senza dispositivi di messa a terra
Equipments provided with double insulation or reinforced insulation without earthing devices



CLASSE III Apparecchi alimentati con tensione di sicurezza inferiore ai 50V
Equipments powered with safety voltage lower than 50V.



Apparecchi idonei a essere montati su superfici normalmente incombustibili
Equipments suitable to be fitted on normally inflammable surfaces.



Prodotti assoggettati alla normativa RAEE/WEEE (2002/96/CE)
Products according to the rules RAEE/WEEE (2002/96/CE)



Tutti i modelli sono depositati / All designs registered

Nella tutela del cliente, IDL EXPORT SRL si riserva il diritto di apportare modifiche e/o migliorie ai prodotti illustrati nel presente catalogo senza alcun obbligo di preavviso. Ogni nostro prodotto viene etichettato secondo le normative vigenti e in esso viene applicato il tagliando di autenticità Made in Italy. Qualsiasi lieve variazione di tonalità imperfezione nei vetri non costituiscono un difetto ma contribuiscono ad esaltarne la complessa lavorazione artigianale.

For our customer protection, IDL EXPORT SRL reserves the right to modify and / or improve to the products shown in this catalogue without notice. Each product is labeled according to the regulations and it is applied authenticity coupon Made in Italy. Any slight variation in color and imperfections in the glasses is not a defect but a contribution to enhance the complex craftsmanship.

TUTELA SUI DIRITTI D'AUTORE. LEGGE 22/4/1941 N°633, LEGGE 14/12/1942 N°1485 PROIBITA
OGNI RIPRODUZIONE ANCHE PARZIALE
SAFEGUARDED BY THE LAW ON COPYRIGHT

IDL EXPORT s.r.l.
via S. Marco, 2
31050 Fanzolo di Vedelago (TV) Italy
T 0039 0423 487141
F 0039 0423 476206
info@idlexport.it
www.idlexport.com

IDL si riserva il diritto di apportare modifiche e/o migliorie ai prodotti illustrati nel presente catalogo senza alcun obbligo di preavviso. IDL reserves the right to make changes and / or improvements to the products described in this catalog without prior notice. Tutela sui diritti d'autore, legge 22/4/1941 n°633, legge 14/12/1942 n°1485. Proibita ogni riproduzione anche parziale. Safeguarded by the law on copyright.



Si ringrazia : ROS ITALIA INTERIORS mobili

IDL EXPORT S.r.l.
Concept and direction: **IDL EXPORT**
Bank image_ **iStockphoto.com**
Photo_ **FISHEYE** Massino Pesce
Print_ **Asolana**
Finished printing_ **Giugno 2016**
E' vietata la riproduzione anche parziale di questo catalogo.
It is forbidden to reproduce any part of this catalogue.